



HALFEN

Halfen HEK3 Precast Coupler

Technical Product Information

Leviat[®]
A CRH COMPANY

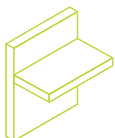

Structural Connections
Precast Connections

English/ Australia

Imagine. Model. Make.

Leviat®

A CRH COMPANY

We imagine, model and make engineered products and innovative construction solutions that help turn architectural visions into reality and enable our construction partners to build better, safer, stronger and faster.

Leviat is a world leader in connecting, fixing, lifting and anchoring technology.

From the build of new schools, hospitals, homes and infrastructure, to the repair and maintenance of heritage structures, our engineering skills are making a difference around the world.

We provide technical design assistance at every stage of a project, from initial planning to installation and beyond.

Our technical support services range from simple product selection through to the development of a fully customised project-specific design solution.

Every promise we make locally, has the commitment and dedication of our global team behind it. We employ almost 3,000 people at 60 locations across North America, Europe and Asia-Pacific, providing an agile and responsive service worldwide.

Leviat, a CRH company, is part of the world's leading building materials business.



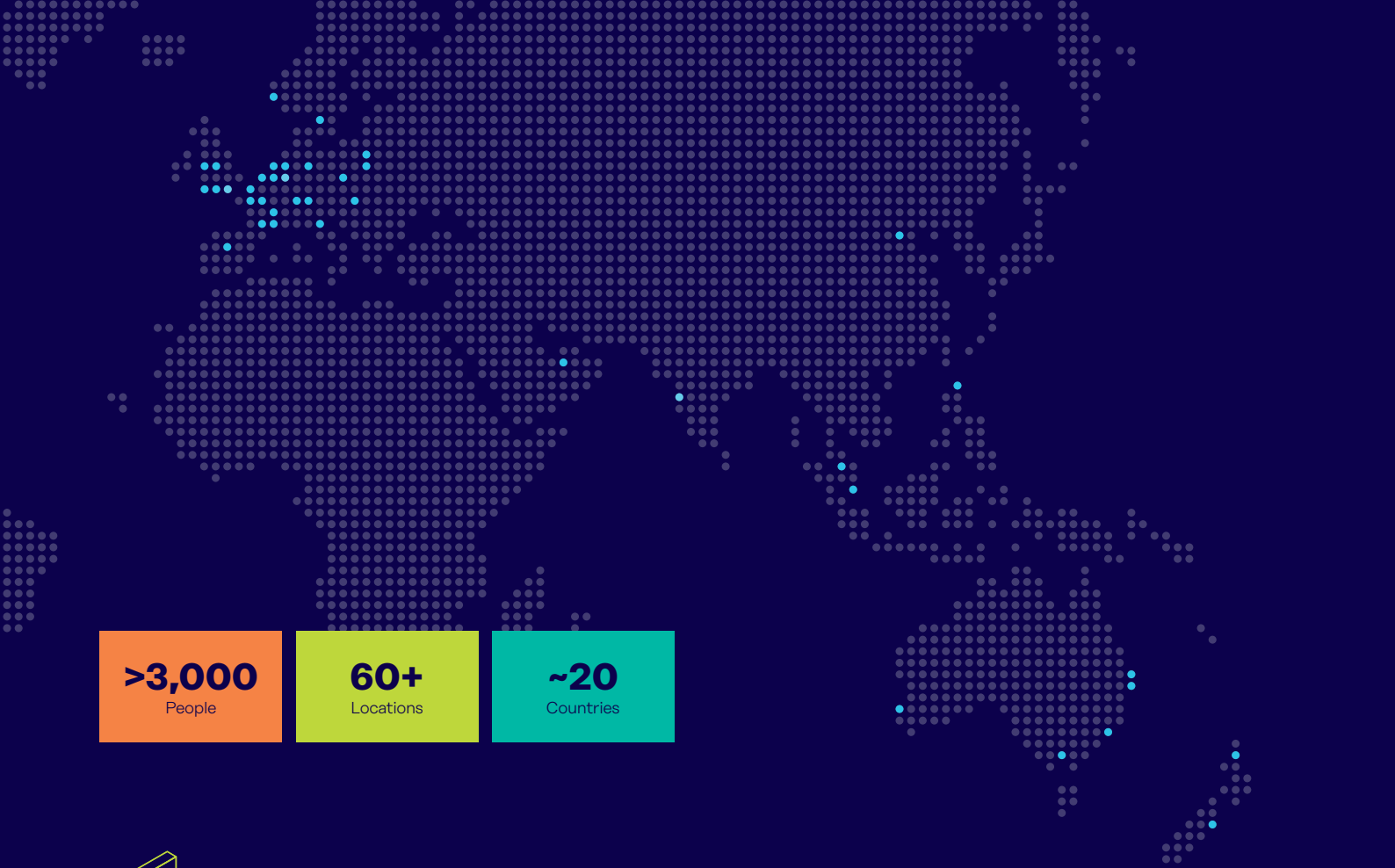

>3,000
People

60+
Locations

~20
Countries

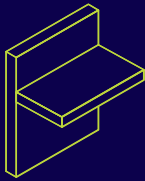

Structural Connections

Systems to form robust, efficient connections, and continuity of concrete reinforcement as necessary, between walls, slabs, columns, beams and balconies, providing structural integrity as well as enhanced thermal and acoustic performance.

- Insulated balcony connectors
- Reinforcing bar couplers
- Concrete Connections
- Reinforcement continuity systems
- Punching shear reinforcement
- Shear load connectors
- Floor Joint Systems
- Precast / Reinforced Columns
- Infrastructure Products
- Precast Connections
- Acoustic dowels and bearings
- Prestress

Other areas of expertise:

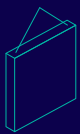

Lifting & Bracing

Systems for the safe and efficient transportation, lifting and temporary bracing of cast concrete elements and tilt-up panels before permanent structural connections are made.



Façade Support & Restraint

Systems for the safe and thermally efficient fixing of the external building envelope, including brick and natural stone, insulated sandwich panels, curtain walling and suspended concrete façades, and also the repair and strengthening of existing masonry installations.

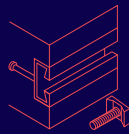

Anchoring & Fixing

Systems for fixing secondary fixtures to concrete, including anchor channels, bolts and inserts; also tension rod systems for roofs and canopies.



Formwork & Site Accessories

Non-structural accessories that complement our engineered solutions and help keep your construction environment operating safely and efficiently, including moulds for casting standard and special concrete elements and construction essentials such as reinforcing bar spacers.

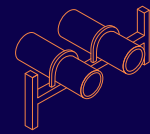

Industrial Technology

Mounting channels, pipe clamps and other versatile framing systems that provide safe fixing in a wide range of industrial applications.

Leviat product ranges:

Ancon | Aschwanden | Connolly | Halfen | Helifix | Isedio | Meadow Burke | Modersohn | Moment | Plaka | Scaldex | Thermomass

Halfen HEK3 Precast Coupler

Contents

Contents

1 General information Page 5–8

The benefits	5
Typical applications	6
Design methods	7
Applications/Corrosion protection	7
Design/Boundary conditions	8

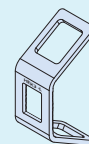

2 Type overview HEK3 Precast couplers 9

HEK3-T/-L	9
-----------	---

3 Accessories 10–11

Accessories	10
Recess formers and height adjustment plates	11

4 Installation/assembly 12–15

Boundary conditions for installation	12
Determine the correct bolt length	12
Installation in the precast plant	13
On-site installation of concrete elements	14
Joint design and Recess fillers (Concrete)	15

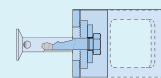

5 Software 16–17

Design basics/Calculation software	16–17
------------------------------------	-------

Contact/Technical support 19

The innovative Halfen HEK3 Precast Coupler

The benefits at a glance

Like its predecessor, the innovative Halfen HEK3 Precast coupler is an efficient solution for dry connection of precast concrete elements, using bolt connectors. However, the overall concept of the HEK3 system has been designed and optimised to increase user-friendliness both in the production process in the precast plant as well as for on-site erection.

Therefore, the innovative HEK3 was designed with a rectangular opening for the bolt. This allows better installation tolerances in both the longitudinal and transverse directions. This is complemented by a new concept for a modular design of the recess formers.



- Bolt and serrated fixing; connections can be immediately subjected to load — faster construction
- dry joints — no mortar required in the joint or in the installation recess
- sufficiently dimensioned installation tolerances
- modular recess concept — uses less space, is adaptable and durable
- more efficient crane use
- faster project completion
- weather independent installation
- reliable planning with calculation in accordance with general building authority approval, Eurocode 2, section 4
- BIM compatible
- HEK3 calculation software and App available
- versatile application, application in reinforced and non-reinforced concrete, strength grade from 20MPa to 50MPa (non-cracked and cracked)
- minimal components thicknesses of 100 mm possible
- no specialist tools required
- architecturally appealing finish, internal components are all but invisible
- concrete elements can be disassembled



HEK3 Precast coupler, application in a dry connection

Halfen HEK3 Precast Coupler

Leviat has a competent team of engineers and technicians to support you in all stages of a project.

Contact us to get the most efficient and economical solution for your project.





Our Technical Support Team will work with you to develop the best connections for a project. Contact addresses can be found at the back of this catalogue.

Or go to our internet site www.leviat.com.

Halfen HEK3 Precast Coupler

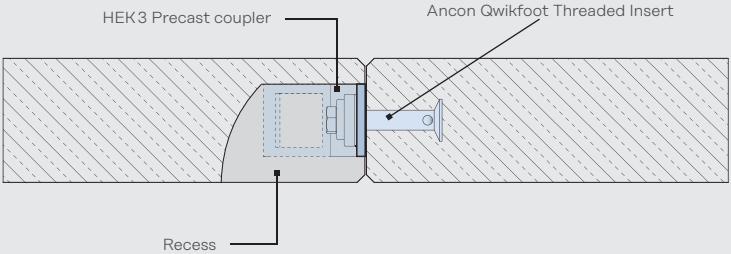
Application Examples

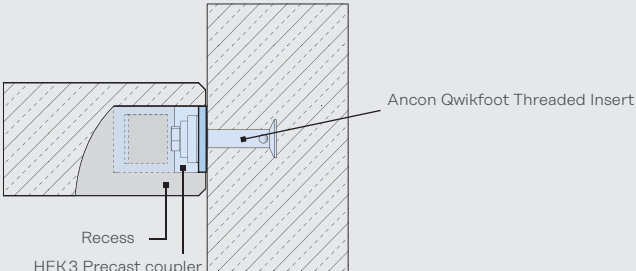
Halfen HEK3 Precast couplers and Ancon QwikFoot and QwikFix Threaded Inserts are optimally matched to ensure efficient connection of minimal thickness precast concrete elements in a wide variety of installation situations.

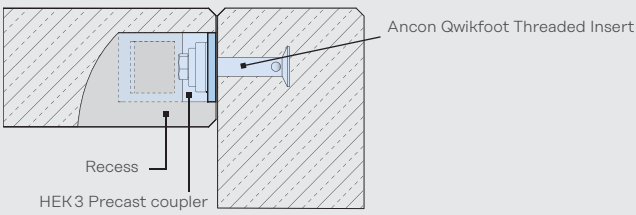
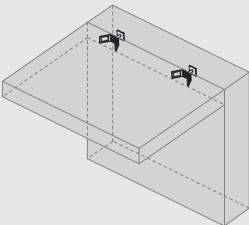
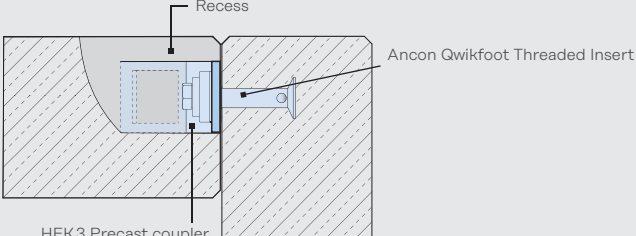
HEK3 Precast coupler in butted connection	
Butt connection – wall to wall	Horizontal section
	
HEK3 Precast coupler in T-connection	
T-connection – wall to wall	Horizontal section
	
Corner connection – wall to wall	Horizontal section
	
Floor-wall connection	Vertical section
	



Please download the "QwikFoot and QwikFix Threaded Inserts" Design Guide for additional information when designing connections using the HEK3 system.
Available at www.ancon.com.au

Halfen HEK3 Precast Coupler

Application Examples

Design method for HEK3 Precast coupler in accordance with EN 1992-4

When designing in accordance with EN 1992-4, the Halfen HEK3 Precast coupler is comparable to an anchor plate with two welded head bolts.

The characteristic resistances and spacings for precast couplers are specified in general building authority approval no. Z-21.8-2086.

Required verifications for tension loads		
Failure type		HEK3 Precast coupler
1	Steel failure of the precast coupler	$N_{Ed} \leq N_{Rd,s}$
2	Concrete failure	$N_{Ed} \leq N_{Rd,c}$
3	Concrete spalling	$N_{Ed} \leq N_{Rd,sp}$
4	Local concrete failure	$N_{Ed} \leq N_{Rd,cb}$

Required verifications for shear loads		
Failure type		HEK3 Precast coupler
1	Steel failure of the precast coupler	$V_{Ed} \leq V_{Rd,s}$
2	Concrete breakout on the side facing away from the load	$V_{Ed} \leq V_{Rd,cp}$
3	Concrete edge failure [ⓐ]	$V_{Ed} \leq V_{Rd,c}$

ⓐ For precast couplers with more than one component edge, verification is only required for the edge distance c_1 in the direction of shear load.

Additional verifications for tension loads

- Steel failure in the reinforcement
- Anchor failure of the reinforcement

Additional verifications for shear loads

- Steel failure in the additional reinforcement
- Bond failure of additional reinforcement

Standard verifications for tension and shear loads

Combination of tension and shear loads

Application / Corrosion protection

The hot-dip galvanised steel precast coupler can only be used in dry interior environments, e.g., in residential projects, offices, schools, hospitals, and commercial projects — wet rooms excepted.

Exposure class and concrete cover for this application are considered Eurocode 2 conform if all steel parts of the HEK3 Precast coupler in the joint and in the recess are completely sealed with grout in accordance with DAfStb** Guideline "Production and Application of Cementitious Concrete Cast and Grout".

Quality is the outstanding feature of our products. All our materials and products are subjected to the most stringent quality control. A quality inspection has verified that our quality management system meets the requirements of the ISO 9001:2015 standard.

Hot dipped galvanised (HDG)

The HEK3 Precast coupler and the matching serrated plate and washer are hot dipped galvanised in accordance with DIN EN ISO 1461 and DAST* Directive 022. The zinc coating has a minimum thickness of 45µm.

Mechanical plated galvanization (MG)

The HEK3 Serrated plates and the washers are mechanically zinc galvanised in accordance with DIN EN ISO 12683. The zinc coating has a minimum thickness of 50µm.



www.szigmhb.de

* DAST: German Committee for Steel Construction

** DAfStb: German Committee for Structural Concrete

Halfen HEK3 Precast Coupler

Dimensioning/Application

Application example HEK3 Precast coupler with Halfen Demu Fixing i.e. bolt anchor

Separate verification is required for the precast coupler, the fixing bolt and Ancon QwikFoot Threaded Insert. We recommend the Threaded Insert Design Guide for more

information on the wide range of Ancon QwikFoot and QwikFix Threaded Inserts.

Download at www.ancon.com.au.

Type of precast connection	HEK3 Precast coupler			Ancon QwikFoot Threaded Insert M16/M20				
	Type	Design resistance N_{Rd} [kN] ①			Type $d_{nom} \times L$ [mm] M16 / M20 ②	Design resistance N_{Rd} [kN] ③		
Design resistances tensile stress only		32MPa	40MPa	50MPa		32MPa	40MPa	50MPa
	HEK3 L-HDG HEK3 T-HDG	14.4	16.2	18.1	QwikFoot FF1670 ④⑤	15.3	17.1	19.1
					QwikFoot FF1696 ④⑤	21.6	24.1	27.0
					QwikFoot FF2070 ④⑤	15.3	17.1	19.1
					QwikFoot FF2096 ④⑤	21.6	24.1	27.0
					QwikFoot FF20120 ④⑥	28.0	31.3	35.0
	HEK3 L-HDG HEK3 T-HDG	21.9	21.9	21.9	QwikFoot FF1670	10.2	11.4	12.7
					QwikFoot FF1696	11.4	12.8	14.3
					QwikFoot FF2070	10.2	11.4	12.7
					QwikFoot FF2096	11.4	12.8	14.3
					QwikFoot FF20120	12.5	13.9	15.6
Design resistances shear stress only, parallel to the joint	Type	Design resistance $V_{Rd,L}$ [kN] ④			Type $d_{nom} \times L$ [mm] M16	Design resistance $V_{Rd,L}$ [kN] ⑤		
		32MPa	40MPa	50MPa		32MPa	40MPa	50MPa
	HEK3 L-HDG	14.4	16.2	18.1	QwikFoot FF1670 ④⑤	21.7	24.2	27.1
					QwikFoot FF1696 ④⑤	30.1	30.1	30.1
	HEK3 L-HDG	26.7	26.7	26.7	QwikFoot FF1670	14.5	16.2	18.1
					QwikFoot FF1696	17.8	19.9	22.3
Design resistances shear stress only, perpendicular to the joint	Type	Design resistance $V_{Rd,T}$ [kN] ①			Type $d_{nom} \times L$ [mm] M16	Design resistance $V_{Rd,T}$ [kN] ⑤		
		32MPa	40MPa	50MPa		32MPa	40MPa	50MPa
	HEK3 T-HDG	26.7	26.7	26.7	QwikFoot FF1670 ④⑤	6.3	7.1	7.9
		12.3 ⑦	13.8 ⑦	15.4 ⑦	QwikFoot FF1696 ④⑤	6.9	7.8	8.7
	HEK3 T-HDG	26.7	26.7	26.7	QwikFoot FF1670	6.3	7.1	7.9
		12.3 ⑦	13.8 ⑦	15.4 ⑦	QwikFoot FF1696	6.9	7.8	8.7

① The resistances given for tensile, or shear stress are design resistance values in accordance with approval Z-21.8-2086; these are for one HEK3 Precast coupler in combination with splitting reinforcement, in compliance with the following boundary conditions; minimal component thickness $h_{min}=100$ edge distance $c_1 = 50$ mm and width of connection joint $t_{2,fix} = 22$ mm, without additional reinforcement. Values only apply for non-cracked concrete.

② If concrete edge failure or concrete pry-out failure cannot be prevented using another method.

③ The resistances given for tensile or shear stress are design resistance values in accordance with AS 3600:2018; these are for a fixing i.e. Threaded Insert installed at component edge with tensile splitting reinforcement and the following boundary conditions; minimal component thickness $h_{min}=100$ (with $c_{nom} = 25$ mm), edge distance $c_1 = 50$ mm and joint width $f = 5$ mm (shear load with cantilever arm $e = 20$ mm). Values only apply for non-cracked concrete, no dense reinforcement (risk of concrete spalling). Installation of Threaded Inserts without nailing plate considered for h_{ef} .

④ Resistances only for tension loads, apply only for concrete reinforced with $\varnothing 10$ reinforcement in accordance with Z-21.8-2086 (Annex 18); not part of the approval.

⑤ Cover reduced to 22mm when Threaded Insert is installed with a nailing plate in components with $h_{min}=100$ thickness.

⑥ Component thickness larger than $h_{min} = 100$ is required to accommodate the length of the Threaded Insert.

⑦ 15mm side cover to HEK3 Precast Coupler in components with $h_{min}=100$ thickness.

Halfen HEK3 Precast Coupler

Product range

Key values for HEK3 Precast couplers				
Type	HEK3-100-L-HDG		HEK3-100-T-HDG	
Material	Steel		Steel	
Finish	HDG		HDG	
Thread	M16	M20	M16	M20
b_E/h_E [mm]	$\geq 100 / \geq 100$		$\geq 100 / \geq 100$	
Steel load capacity of the precast coupler*				
$N_{Rd,s}$ [kN]	21.96		21.96	
	34.02 ^①	37.99 ^①	34.02 ^①	37.99 ^①
$V_{Rd,s}$ [kN]	26.73		26.73	
Geometry [mm]				
h_{ef}	83		83	
s_{ef}	200		200	
h_{nom}	100		100	
b_0/l_0 [mm]	40/50		40/50	
b	70		70	
l	213		213	
t	8		8	
$t_{2,fix}$	22		22	
h_R	≤ 125		≤ 125	
b_R	74		74	
t_R	72		72	

* The load-bearing capacity for the concrete must be verified using the Halfen Software for each application (taking the geometric boundary conditions into account).

b_E/h_E = section, precast component

① Only applies for centric tensile loads.

Halfen HEK3 Precast Coupler

Product range/accessories

HEK3 Fixing sets (Formwork)

The threaded rod can also be used as a tool to lever recess formers out of the finished concrete elements after removing the formwork. Can be used for all HEK3 Recess formers.

Standard threaded rod M10
(min. L = 200mm)
+ nut and washer
supplied by customer.

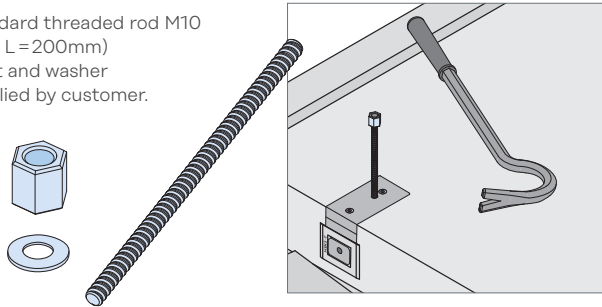

Slotted shims for HEK3

Shims suitable for HEK3-T/-L, Steel, (HDG).

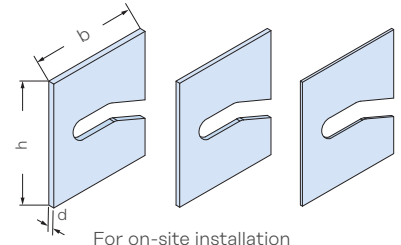

For on-site installation

Article name	d [mm]	h [mm]	b [mm]
HEK3-SW-100-17×2-HDG	2		
HEK3-SW-100-17×3-HDG	3	85	100
HEK3-SW-100-17×5-HDG	5		

Washer for HEK3

Washers, suitable for HEK3-T/-L with bolt hole hot-dipped galvanised.

Integral part of the HEK3 system.

Installation is essential.

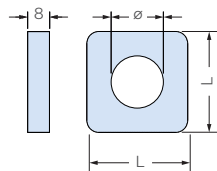

Article name	ø [mm]	L [mm]
HEK3-100-W-17-HDG	17	36
HEK3-100-W-21-HDG	21	45

Serrated plate for HEK3

Brackets, suitable for HEK3-T/-L, serrated and with slot for the bolt; steel, mechanically plated.

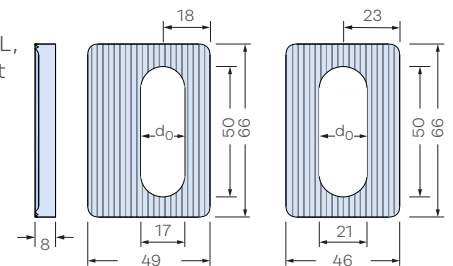

Article name	d ₀ [mm]
HEK3-100-C-17-MG	17
HEK3-100-C-21-MG	21

HEK3 Recess filler mould

Reusable moulds (Polyurethane) to make recess fillers.

Fillers can be made using the same material as a slab for an aesthetic finish.

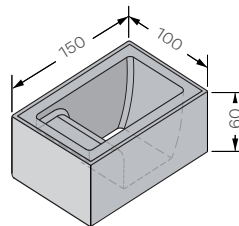

Article name
HEK3-100-RF-Mould

Dimension — installation recess

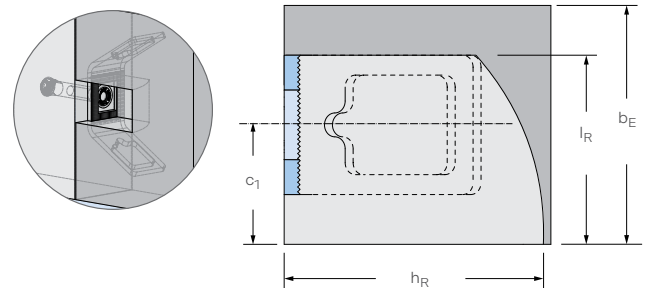

Halfen HEK3 Precast Coupler

Product range/Recess formers

Plastic recess former with screw fixing

Reusable plastic recess formers suitable for application in non-magnetic formwork

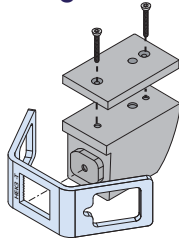
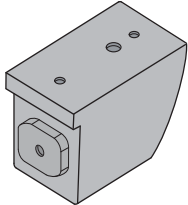

Modular system with a base body suitable for an installation depth of 50 mm, optionally adaptable with height adjustment plates.

Article name	c ₁ [mm]	b _E [mm]	l _R [mm]	h _R [mm]
HEK3-100-RF-BB	50	100	86	125

Height adjustment plate / screw fixing former

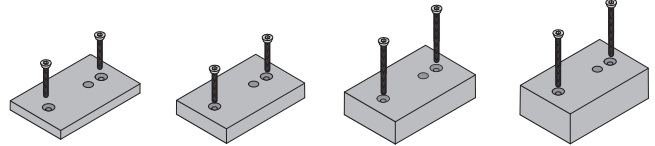

Article name	h [mm]	b _E [mm]
HEK3-100-RF-HA 10-SET ②	10	120
HEK3-100-RF-HA 20-SET ②	20	140
HEK3-100-RF-HA 30-SET ③	30	160
HEK3-100-RF-HA 40-SET ③	40	180

Height adjuster

- ② Incl. 2 screws ø6mm L = 30mm
- ③ Incl. 2 screws ø6mm L = 50mm

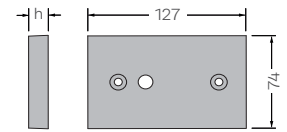

Recess former with magnets ①

Reusable plastic recess formers for application in steel formwork with self-compacting concrete

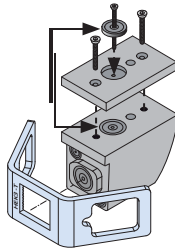
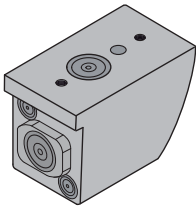

Modular system with a base body suitable for an installation depth of 50 mm, optionally adaptable with height adjustment plates. ①

Article name	c ₁ [mm]	b _E [mm]	l _R [mm]	h _R [mm]
HEK3-100-RF-BB-MAG	50	100	86	125

① Incl. 1 removable magnet and ø5mm screw L=50mm

Height adjustment plate / magnetic recess former

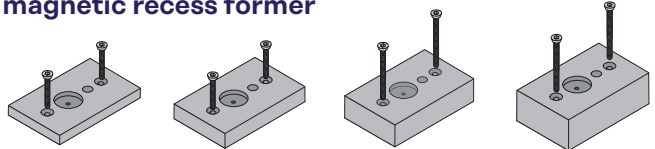

Article name	h [mm]	b _E [mm]
HEK3-100-RF-HA 10-MAG-SET ②	10	120
HEK3-100-RF-HA 20-MAG-SET ②	20	140
HEK3-100-RF-HA 30-MAG-SET ③	30	160
HEK3-100-RF-HA 40-MAG-SET ③	40	180

Height adjuster with magnet recess

- ② Incl. 2 screws ø6mm L = 30mm
- ③ Incl. 2 screws ø6mm L = 50mm

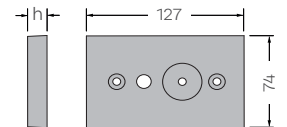

Recess former with strong magnets

Reusable recess former made of polyurethane with strong magnet for applications requiring increased adhesive force.

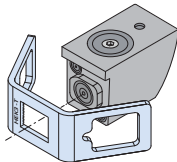
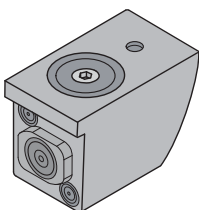

Article name	c ₁ [mm]	b _E [mm]	l _R [mm]	h _R [mm]
HEK3-100-RF-BB-MAG-S	50	100	86	125

Height adjustment plates for 4 installation depths*

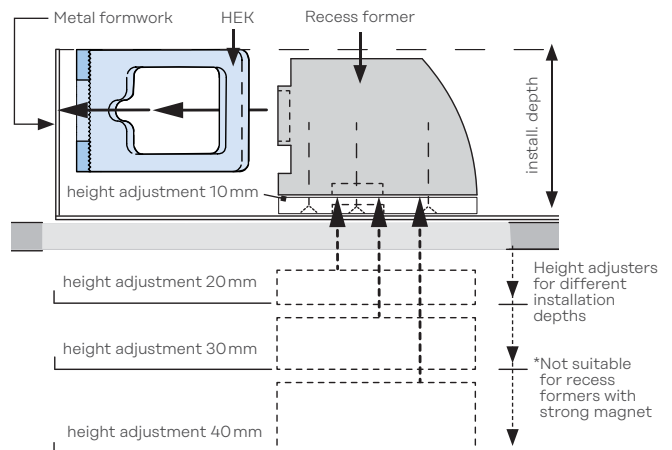

Halfen HEK3 Precast Coupler

Installation instructions

Installing the precast couplers

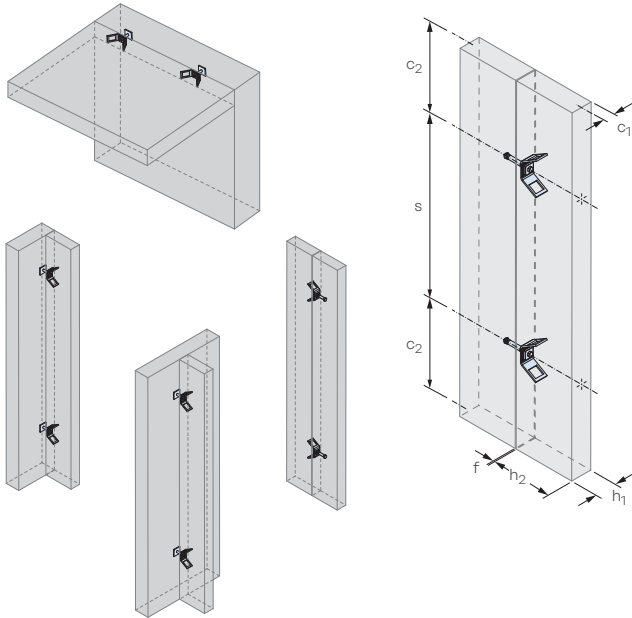

- concrete strength grade from 20MPa to 50MPa
- element thickness $h_1 \geq 100$ mm
- width of joint $f \leq 20$ mm
- edge distance at right angle to joint $c_1 \geq 50$ mm
- edge distance parallel to joint $c_2 \geq 225$ mm
- axial spacing parallel to joint $s \geq 450$ mm
- at least two HEK3 Precast couplers in a joint
- HEK3 Recess formers can be used
- suitable bolts M16/M20
- element height $h_2 = \text{min. } 100$ mm
- install with the specified installation torque T_{inst} (see the table on page 14 or the installation instructions)

Finding the required bolt length

The precast coupler is anchored using a fixing bolt screwed into an anchor previously cast in a second concrete element. The bolt and the anchor must be selected and cast in as specified by the responsible planning engineer. The required bolt length must be verified.

Required bolt length L_s

$$L_{s,\text{min}} = s + t_{1,\text{fix}} + t_{2,\text{fix}} \text{ (minimum bolt length)}$$

$$L_{s,\text{max}} = a + t_{1,\text{fix}} + t_{2,\text{fix}} \text{ (minimum bolt length)}$$

- s = minimum screw-in depth of the fixing bolt in the anchor sleeve according to the manufacturer's specification
- a = maximum screw-in depth of the fixing bolt in the anchor sleeve according to the manufacturer's specification
- $t_{1,\text{fix}}$ = width of the connection
- $t_{2,\text{fix}}$ = 22 mm
Clamp size of the precast coupler with serrated plate and washer (see table on page 9)

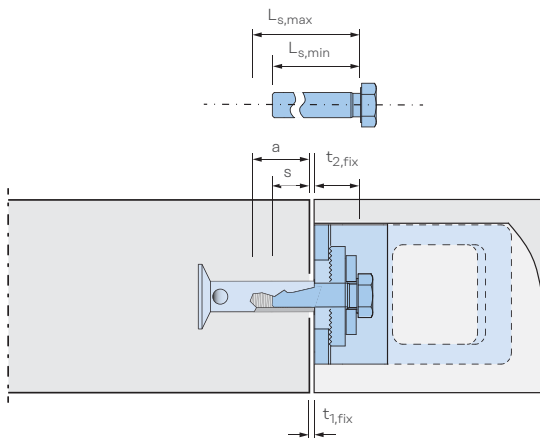

Required bolt lengths L_s [mm]

Joint (gap) width [mm]	0	5	10	15	20
Ancon QwikFoot Threaded Insert	Bolt lengths				
FF1670Z / FF1670G	50	55	60	65	70
FF1696ZH	50	55	60	65	70
FF1696G	50	55	60	65	70
FF2070ZH / FF2070G	50	55	60	65	70
FF2096ZH / FF2096G	55	60	65	70	75
FF20120ZH / FF20120G	55	60	65	70	75

Halfen HEK3 Precast Coupler

Installation instructions

Face-down production in the precast plant (wood/timber formwork)

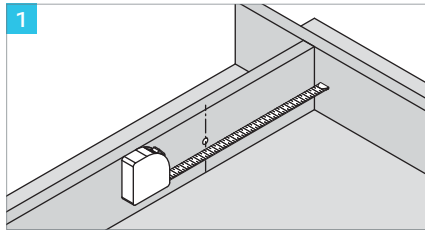

1 Locate the exact position for the precast coupler and drill an 11mm hole for the fixing rod/bolt in the formwork.

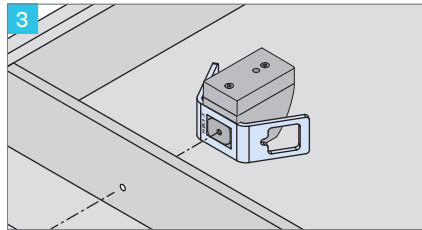

3 Grease the serrated surface of the HEK3 and press on to the recess former.

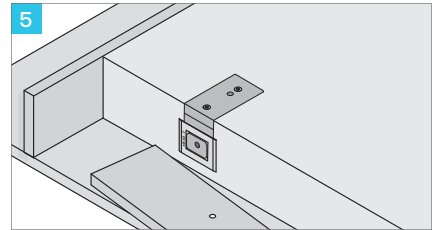

5 After the concrete has hardened, loosen the fixings and remove the formwork from the component.

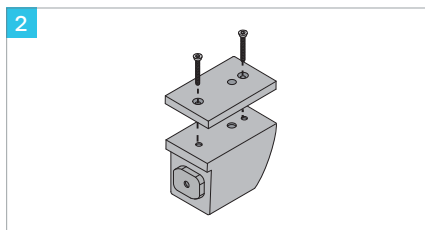

2 Fix the correct height adjuster to the recess former for installation depths >50mm (see page 11). Always use ample formwork grease.

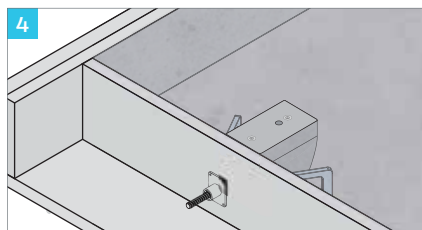

4 Fix the recess formers with the attached HEK3 to the formwork with a threaded rod or 10mm bolt.

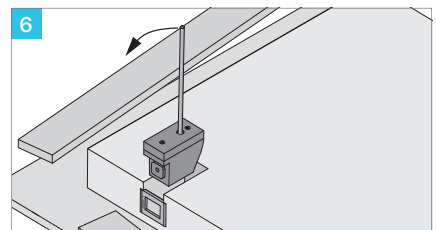

6 Recess formers in positive cast elements can be removed before lifting. Screw a M10 rod in the recess former for easy removal.

Face-up production the precast plant (Metal formwork)

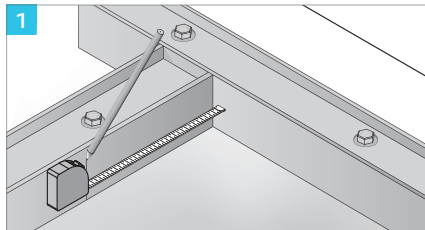

1 Measure and mark the exact specified position for the HEK3 on the metal formwork.

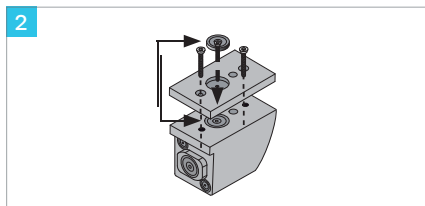

2 Fix the correct height adjuster to the recess former for installation depths >50mm (see page 11). Always use ample formwork grease.

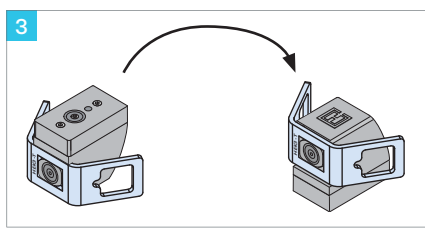

3 Grease the serrated surface of the HEK3 and press on to the recess former; turn the right way up as illustrated (orientate the magnets towards the formwork).

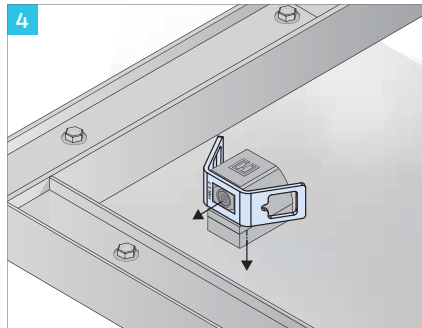

4 Place the HEK3 with the recess former at the exact specified position on the formwork.

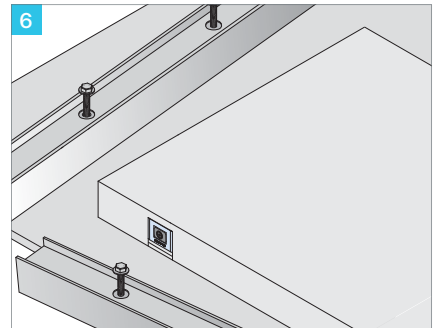

6 After the concrete has hardened; remove the formwork.

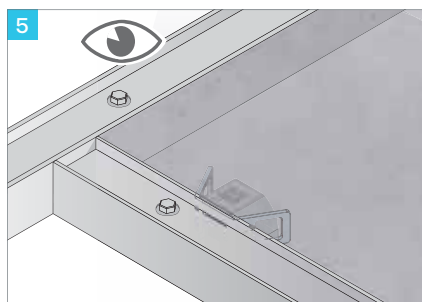

5 Check that all recess formers are at the specified positions and securely attached to the formwork.

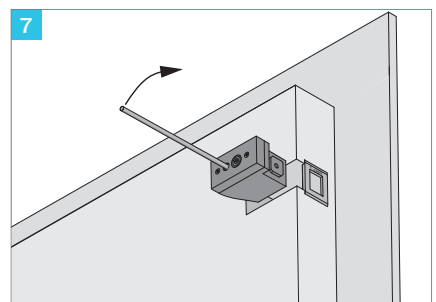

7 Tilt-up/raise the precast component to access the recess former. Screw a M10 threaded rod in the top of the recess former for easy removal.

Halfen HEK3 Precast Coupler

Installation instructions

On-site installation

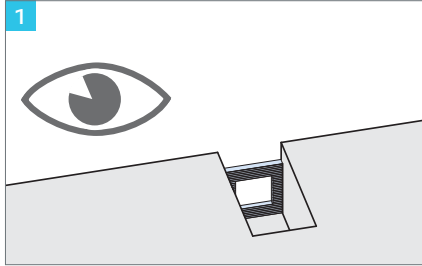

Ensure the serrated surfaces in the HEK3 Precast coupler are clean; remove any concrete or other residue.

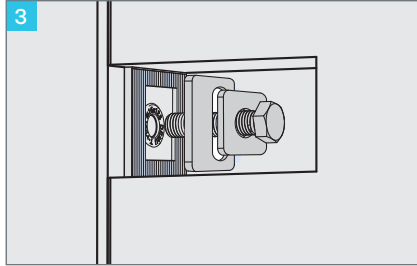

Insert the serrated plate with the washer and the bolt, through the installation access hole and screw the bolt into the Threaded Insert. Ensure the correct length of bolt is used (see page 12).

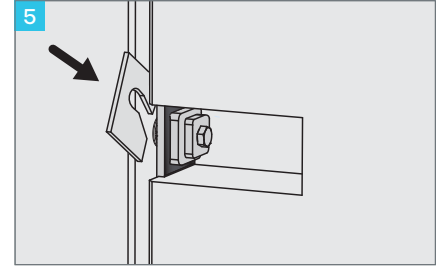

If necessary, use slotted shims between the precast coupler and the Threaded Insert.

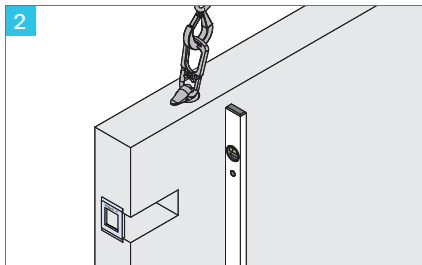

Install and adjust the concrete element.

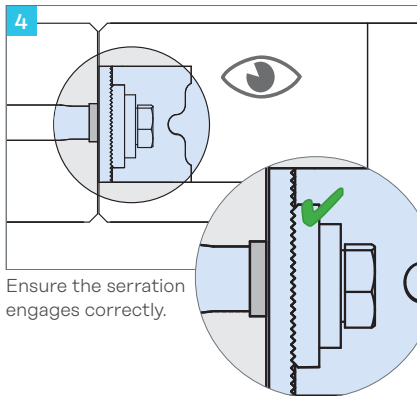

Ensure the serration engages correctly.

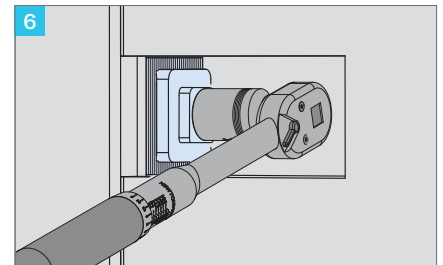

Observe the installation torques T_{inst} for the HEK3 Precast coupler (see table).

Installation torques T_{inst} [Nm]	
Bolt thread	T_{inst}
M16	75
M20	125

Installation torques are valid for unlubricated bolts. Adequate shims are recommended to compensate for excess joint widths or recessed fixing anchors when tightening the HEK3 Precast couplers.

The recommended values include specific losses caused by bolt relaxation resulting from settlement in the bolted connections.

Halfen HEK3 Precast Coupler

Installation instructions

Joint design — sealing the HEK3 installation recesses

To ensure reliable load transfer, any gap under the contact surface of the HEK3 must be completely shimmed with the appropriate slotted shims (see page 10). Depending on the requirements for thermal insulation, fire protection and water and air tightness, use suitable filling materials and sealants in accordance with the manufacturer's instructions to close the remaining joint.

After correct installation, the recess with all parts of the HEK3 Precast coupler must be completely sealed using grout in accordance with the DAfStb* guideline 'Production and use of cement-bound grout concrete and grout'.

We recommend using precast HEK3 Recess fillers if an aesthetic finish of the precast elements (fair-face concrete) is a priority or if easy disassembly of the elements is specified.

*DAfStb: German Committee for Structural Concrete

Recess fillers in concrete for HEK3

Reusable polyurethane moulds are available to make recess fillers in the precast plant using concrete from the same pour as the concrete element.

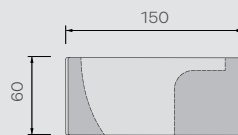
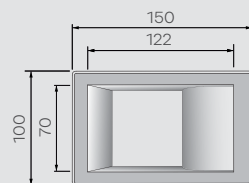
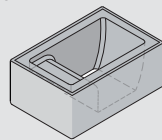

Dimensions = mm

The recess fillers mould can be used from both sides. Depending on the desired surface finish this can be smooth or made to match the surface of the concrete element.

The moulds can be used individually or...

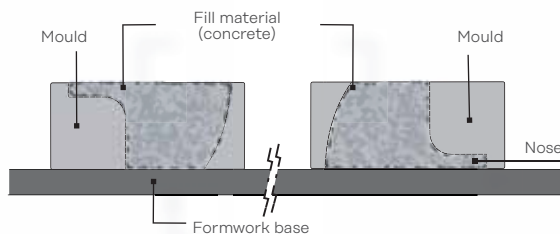

... multiple moulds can be fixed to an auxiliary aid with M10 Bolts to make a larger number of recess fillers more efficiently.

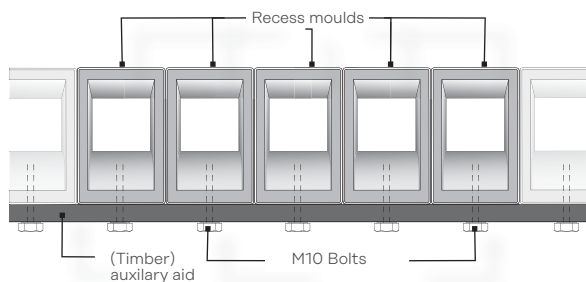

For permanent connections

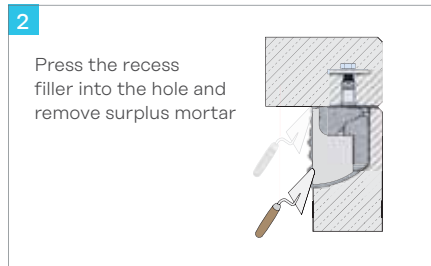
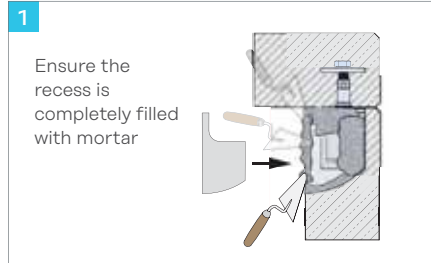

For non-permanent connections. Disassembling the concrete elements

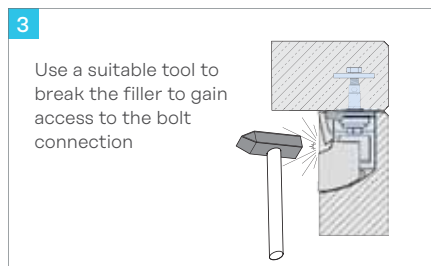
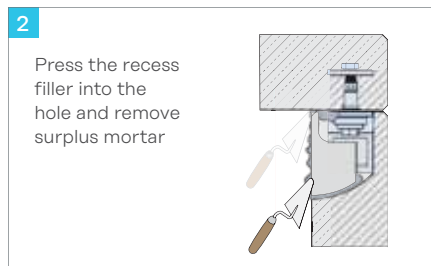
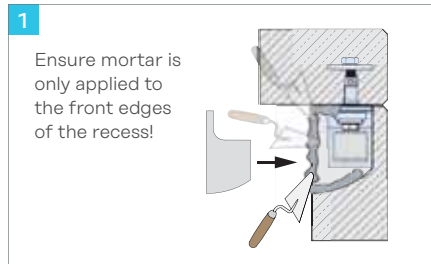

Halfen HEK3 Precast Coupler

Software

Halfen Calculation software for design of precast connections using HEK3 Precast couplers and Halfen Demu Sleeve and bolt anchors are easy-to-use, very powerful tools, and ensure planners get economic and reliable results for their projects.

Benefits

The program is used to calculate the connection between two precast concrete construction elements. The required verifications for the selected HEK3 Precast coupler and the Halfen Demu Anchor element are based on EN 1992-4 and are verified and checked separately.

Boundary conditions

Calculation takes all necessary boundary conditions into account, for example:

- design stress resultant in the connection: N_{Ed} and V_{Ed}
- type of precast connection: T-connection or butt-connection
- butt-connection or right-angled connection of the precast component
- verification of fixing bolts
- general and building component dimensions, especially edge distances
- gap width of the joint
- concrete strength and concrete cover of the precast elements
- anchorage material: cracked and non-cracked
- individual consideration of existing edge and stirrup reinforcement
- type and method of additional reinforcement at the anchorage points

Precast couplers and anchorage elements

A precast connection can consist of two HEK3 precast couplers. Alternatively, one HEK3 Precast coupler can be used in combination with a Halfen Demu Anchor element. Select from the following types:

- Halfen Demu T-FIXX® Sleeve anchor
- Halfen Demu Bolt anchors 1988 and 1980-P

Data input

The input for geometry, type of connection and loads are interactive with simultaneous plausibility check. All input is interactively displayed directly in a 3D window. Changes can be made directly in the graphic display.

Results

After calculation has been completed, all information important for the planning process, design drawings and intermediate design results can be displayed in their entirety. The option to display a detailed output, can provide more clarity and ensure complete traceability of the verifications. Results from incomplete verification are marked in red.



Splash screen with language option



Programm GUI

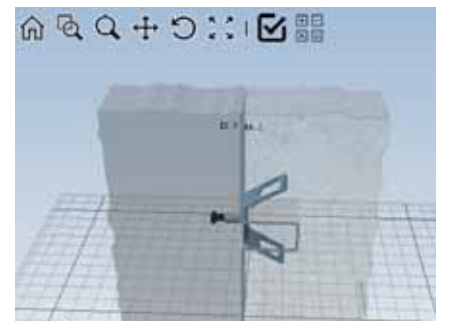

3D display of the precast coupler



Print preview: Result report

Halfen HEK3 Precast Coupler

Software/Tender texts

Visual Control

All necessary verifications for the selected precast coupler and anchor are clearly displayed in a "Results" tab.

Results for verifications not meeting the criteria are marked in red (for load factors larger than 100%.) Click on individual verifications to display detailed information.

Results printout

A condensed or a verifiable, more detailed printout are available. The short version includes an overview of the boundary conditions, construction drawings, 3D graphics, geometry, loads and all necessary verifications. In the more detailed version, all results are presented in a verifiable format. Both versions can be exported as .xls files.

Software Version

The latest version of the calculation program can be downloaded from the Internet at the following address: www.halfen.com.

The software currently only displays the Halfen T-FIXX® Fixing Anchor range. Equivalent size and length of Ancon QwikFoot or QwikFix Threaded Inserts can be used instead. These are more readily available in Australia. The Halfen T-FIXX® Anchors can also be supplied if preferred however lead times will apply.

At the time of catalogue release the program has the option of running in the following languages:

- English
- German
- Dutch
- Polish

System requirements:

- Windows 8, 10 or 11 with current Service Packs installed
- installed NET Framework 4.72
- installed DirectX® DX 11 recommended feature level 10.1
- 4 GB RAM/1.800 MHz
- screen resolution 1024 × 786 px

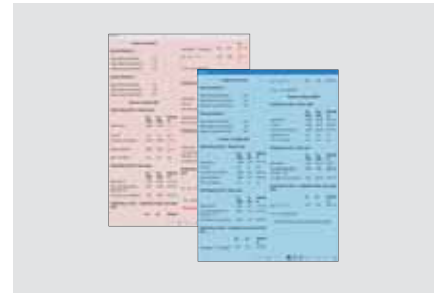

Presentation of results



Design software

Tender text (selected)

Halfen HEK3 Precast coupler, type HEK3-100-L-HDG

Halfen HEK3 Precast coupler with general building authority approval Z-21.8-2086 for connection of precast concrete components under static and quasi-static loads in reinforced and non-reinforced normal concrete in strength class C20/25 to C50/60; type HEK3-100-L-HDG

with

L-100 = serrated surface for efficient transfer and anchorage of longitudinal and shear loads parallel to the joint,

HDG = corrosion protection; HDG Hot dipped galvanised,

or similar, deliver and install in accordance with the manufacturer's installation instructions.



Leviat®

Innovative engineered products
and construction solutions that
allow the industry to build safer,
stronger and faster.



Worldwide contacts for Leviat

Australia

98 Kurrajong Avenue,
Mount Druitt, Sydney, NSW 2770
Tel: +61 - 2 8808 3100
Email: info.au@leviat.com

Austria

Leonard-Bernstein-Str. 10
Saturn Tower, 1220 Wien
Tel: +43 - 1 - 259 6770
Email: info.at@leviat.com

Belgium

Industrielaan 2
1740 Ternat
Tel: +32 - 2 - 582 29 45
Email: info.be@leviat.com

China

Room 601 Tower D, Vantone Centre
No. A6 Chao Yang Men Wai Street
Chaoyang District
Beijing · P.R. China 100020
Tel: +86 - 10 5907 3200
Email: info.cn@leviat.com

Czech Republic

Pekařská 695/10a
155 00 Praha 5
Tel: +420 - 311 - 690 060
Email: info.cz@leviat.com

Finland

Vädursgatan 5
412 50 Göteborg / Sweden
Tel: +358 (0)10 6338781
Email: info.fi@leviat.com

France

6, Rue de Cabanis
31240 L'Union
Tel: +33 (0)5 34 25 54 82
Email: info.fr@leviat.com

Germany

Liebigstrasse 14
40764 Langenfeld
Tel: +49 - 2173 - 970 - 0
Email: info.de@leviat.com

India

Unit S4, 902, A Wing,
Lodha iThink Techno Campus Building,
Panchpakhadi, Pokharan Road 2,
Thane, 400606
Tel: +91-022 695 33700
Email: info.in@leviat.com

Italy

Via F.lli Bronzetti 28
24124 Bergamo
Tel: +39 - 035 - 0760711
Email: info.it@leviat.com

Malaysia

28 Jalan Anggerik Mokara 31/59
Kota Kemuning, 40460 Shah Alam
Selangor
Tel: +603 - 5122 4182
Email: info.my@leviat.com

Netherlands

Oostermaat 3
7623 CS Borne
Tel: +31 - 74 - 267 14 49
Email: info.nl@leviat.com

New Zealand

246D James Fletcher Drive, Otahuhu,
Auckland 2024
Tel: +64 - 9 276 2236
Email: info.nz@leviat.com

Norway

Vestre Svanholmen 5
4313 Sandnes
Tel: +47 - 51 82 34 00
Email: info.no@leviat.com

Philippines

27F Office A, Podium West Tower,
12 ADB Avenue, Ortigas Center
Mandaluyong City, 1550
Tel: +63 - 2 7957 6381
Email: info.ph@leviat.com

Poland

Ul. Obornicka 287
60-691 Poznań
Tel: +48 - 61 - 622 14 14
Email: info.pl@leviat.com

Singapore

10 Benoi Sector,
Singapore 629845
Tel: +65 - 6266 6802
Email: info.sg@leviat.com

Spain

Polígono Industrial Santa Ana
c/ Ignacio Zuloaga, 20
28522 Rivas-Vaciamadrid
Tel: +34 - 91 632 18 40
Email: info.es@leviat.com

Sweden

Vädursgatan 5
412 50 Göteborg
Tel: +46 - 31 - 98 58 00
Email: info.se@leviat.com

Switzerland

Hertistrasse 25
8304 Wallisellen
Tel: +41 (0)800 22 66 00
Email: info.ch@leviat.com

United Arab Emirates

RA08 TB02, PO Box 17225
JAFZA, Jebel Ali, Dubai
Tel: +971 (0)4 883 4346
Email: info.ae@leviat.com

United Kingdom

President Way,
President Park,
Sheffield S4 7UR
Tel: +44 - 1582 - 470 300
Email: info.uk@leviat.com

USA / Canada

6467 S Falkenburg Road
Riverview, FL 33578
Tel: (800) 423-9140
Email: info.us@leviat.us

For countries not listed

Email: info@leviat.com

Notes regarding this catalogue

© Protected by copyright. The construction applications and details provided in this publication are indicative only. In every case, project working details should be entrusted to appropriately qualified and experienced persons.

Whilst every care has been exercised in the preparation of this publication to ensure that any advice, recommendations or information is accurate, no liability or responsibility of any kind is accepted by Leviat for inaccuracies or printing errors. Technical and design changes are reserved. With a policy of continuous product development, Leviat reserves the right to modify product design and specification at any time.

