

Structural Connections
Punching Shear Reinforcement

Leviat[®]
A CRH COMPANY

Ancon[®]

Ancon Shearfix Punching Shear Reinforcement



**Design
Program
Available**

Imagine. Model. Make.

Leviat®

A CRH COMPANY

We imagine, model and make engineered products and innovative construction solutions that help turn architectural visions into reality and enable our construction partners to build better, safer, stronger and faster.

Leviat is a world leader in connecting, fixing, lifting and anchoring technology.

From the build of new schools, hospitals, homes and infrastructure, to the repair and maintenance of heritage structures, our engineering skills are making a difference around the world.

We provide technical design assistance at every stage of a project, from initial planning to installation and beyond.

Our technical support services range from simple product selection through to the development of a fully customised project-specific design solution.

Every promise we make locally, has the commitment and dedication of our global team behind it. We employ almost 3,000 people at 60 locations across North America, Europe and Asia-Pacific, providing an agile and responsive service worldwide.

Leviat, a CRH company, is part of the world's leading building materials business.





>3,000
People

60+
Locations

~20
Countries

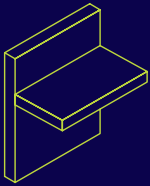

Structural Connections

Systems to form robust, efficient connections, and continuity of concrete reinforcement as necessary, between walls, slabs, columns, beams and balconies, providing structural integrity as well as enhanced thermal and acoustic performance.

- Insulated balcony connectors
- Reinforcing bar couplers
- Concrete Connections
- Reinforcement continuity systems
- Punching shear reinforcement
- Shear load connectors
- Floor Joint Systems
- Precast / Reinforced Columns
- Infrastructure Products
- Precast Connections
- Acoustic dowels and bearings
- Prestress

Other areas of expertise:

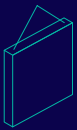

Lifting & Bracing

Systems for the safe and efficient transportation, lifting and temporary bracing of cast concrete elements and tilt-up panels before permanent structural connections are made.



Façade Support & Restraint

Systems for the safe and thermally-efficient fixing of the external building envelope, including brick and natural stone, insulated sandwich panels, curtain walling and suspended concrete façades, and also the repair and strengthening of existing masonry installations.



Anchoring & Fixing

Systems for fixing secondary fixtures to concrete, including anchor channels, bolts and inserts; also tension rod systems for roofs and canopies.



Formwork & Site Accessories

Non-structural accessories that complement our engineered solutions and help keep your construction environment operating safely and efficiently, including moulds for casting standard and special concrete elements and construction essentials such as reinforcing bar spacers.

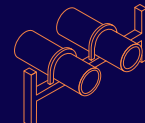

Industrial Technology

Mounting channels, pipe clamps and other versatile framing systems that provide safe fixing in a wide range of industrial applications.

Leviat product ranges:

Ancon | Aschwanden | Connolly | Halfen | Helifix | Isedio | Meadow Burke | Modersohn | Moment | Plaka | Scaldex | Thermomass

Punching Shear Reinforcement

Contents

Ancon Shearfix Punching Shear	6
Comparison with Shear Links	6
System Components	7
Product Identification	7
Design Program	8-9
Design Information	10
Calculation Method	11
Typical Arrangements	12
Installation Procedure	12
Applications	13
Other Ancon Products	13

Reinforcing Concrete Slabs at Column Heads

Slab loads induce shear stresses into the slab section around columns. If these stresses exceed the concrete shear capacity, and where additional reinforcement is not provided, the column would 'punch' through the slab. This punching shear is similarly induced in the footing on which the column bears.

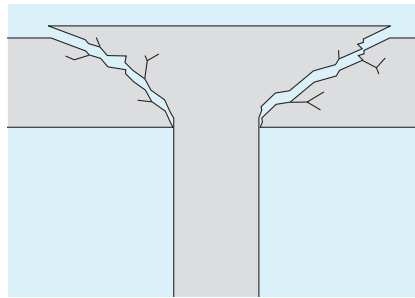

Although punching shear can be relieved by localised thickening of the concrete with downstand beams and enlarged column heads, the construction of flat slabs offers many advantages. A consistent head space can reduce the overall height of a building and provide significant time and material savings.

Used within a slab to provide additional reinforcement around columns, Ancon Shearfix is the ideal solution to the design and construction problems associated with punching shear.

The system consists of double-headed studs welded to flat rails, positioned around the column head or base. The shear load from the slab is transferred through the studs into the column.

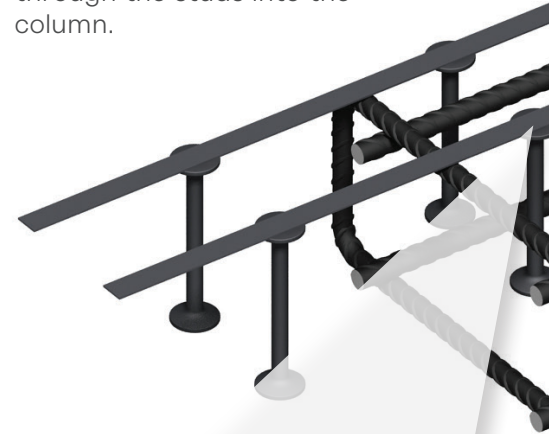



Established, trusted name in concrete reinforcement



Free AS3600, ACI318, EC2 design program & technical support



BIM Objects available



Full material traceability



In-house, traceable batch testing



Punching Shear Reinforcement

Ancon Shearfix

Used within a slab to provide additional reinforcement around columns, Ancon Shearfix is the ideal solution to the design and construction problems associated with punching shear.

The system consists of double-headed studs welded to flat rails, positioned around the column head or base. The shear load from the slab is transferred through the studs into the column.

Shearfix is suitable for all column shapes and is easy to install either 'top down' or 'bottom up', depending on user preference.

Comparison with Shear Links

Ancon Shearfix offers many advantages over loose shear links. Links can be time-consuming to both design and install. An Ancon Shearfix system is easily detailed with our Punching Shear Reinforcement Design Program (see pages 8-9). This program generates a layout drawing for inclusion in the building plans and, rather than being installed individually, these studs are supplied to site welded to rails at the appropriate spacing.

When comparing links with studs, research has shown that any additional material costs incurred when purchasing a prefabricated stud system, such as Ancon Shearfix, are generally far outweighed by the savings from a significantly reduced fixing time; these systems being up to ten times quicker to install (source: British Cement Association: Prefabricated punching shear reinforcement for reinforced concrete flat slabs. BCA, Camberley, 2001).



System Components

The Ancon Shearfix system comprises double-headed studs welded to flat rails. It is manufactured to suit the specific requirements of each application. The quantity of each component, the dimensions and spacings, and the layout pattern around the column are determined by calculation. Free software is available to determine the optimum system design.

Ancon Shearfix Studs

Studs are manufactured in four diameters (12, 16, 20 and 24mm) from Grade 500N reinforcing bar. The heads are hot forged to three times the diameter of the bar. Studs are manufactured in custom heights to suit the slab thickness. The minimum stud height depends on the stud diameter. The following table lists the minimum stud heights as well as the respective minimum slab thickness.

Stud Diameter	Min Stud Height	Min Slab Thickness
12mm	95mm	140mm
16mm	95mm	140mm
20mm	135mm	180mm
24mm	375mm	420mm

Note: minimum slab thickness on 20mm clear cover to rail / stud

Ancon Shearfix Rails

The studs are welded to the rail at the centres determined by our software or a design calculation. The rail performs no structural function but ensures stud alignment and positioning within the slab.

Project Management

Please contact us if you would like help in creating an Ancon Shearfix schedule and a programme for delivery to suit progress on site. If advised at the time of ordering, pallets can be packed in priority order e.g by pour number.

Please call us on 1300 304 320 or contact orders.au@leviat.com with your Ancon Shearfix enquiry.

Building Information Modelling (BIM)

For a BIM Object of the Ancon Shearfix system, please visit www.ancon.com.au/downloads/bim-object-library.

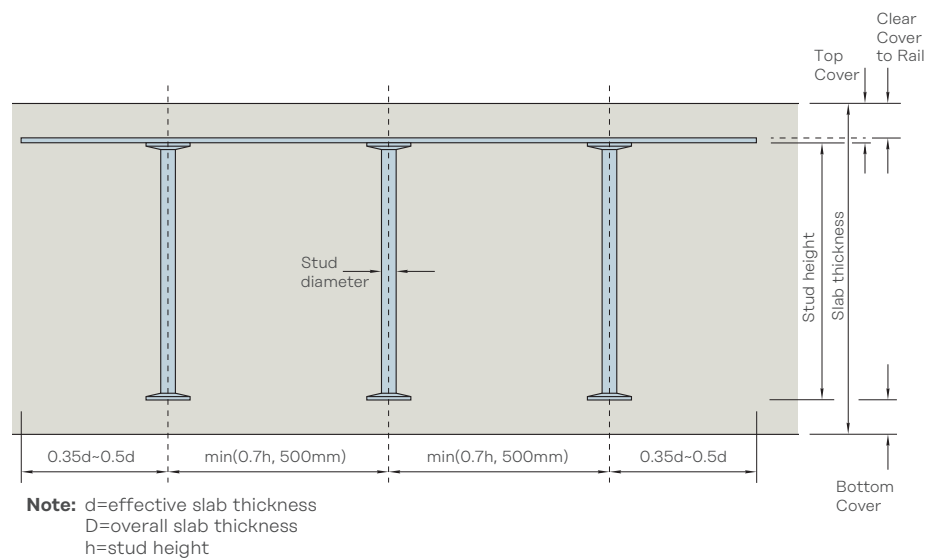
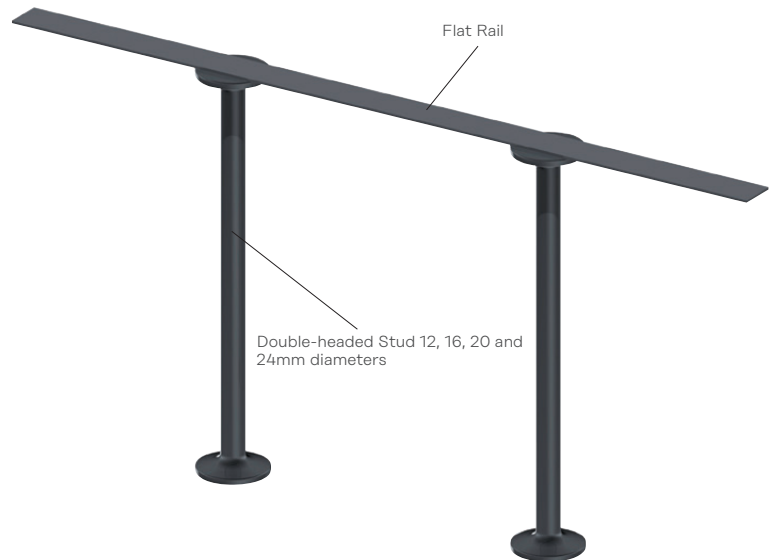

Product Identification

Each rail of studs carries the following identification:

Ancon Shearfix Code, Stud Diameter x Stud Height, Number of Studs @ Stud Centres, Rail Length

e.g. Ancon SF12 x 235, 3 @ 160 c/c, 564 long

All dimensions are in millimetres.

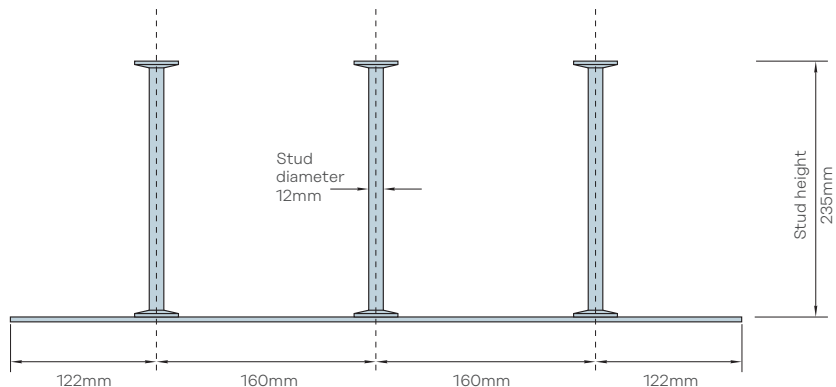

Ancon SF12 x 235, 3 @ 160 c/c, 564 long

Punching Shear Reinforcement

Design Program (Version 6 Release)

Ancon Shearfix is designed to suit the specific requirements of each application. We provide a free design program to simplify the specification and ordering of a Shearfix system.

This easy-to-use program allows the optimum system design to be determined and generates a printable calculation sheet, a DXF file and a parts list of the specified layout. Solutions can be created for a wide range of column sizes, shapes and locations including corner and edge columns with and without offset.

The following combinations of column shape and location are permissible in the Ancon Shearfix Design Program.

Column location	Column shape	
	Rectangular	Circular
Internal	✓	✓
Edge	✓	✓
Corner	✓	✓
Re-entrant corner	✓	✓

The program allows analysis to AS3600 (Lim and Rangan), ACI 318 and BS EN 1992 (Eurocode 2).

Where there are openings close to the column, a section of the slab will be ineffective and perimeters will need to be reduced; the Ancon design program allows these reductions to be applied to each perimeter.

The program requires the following information and is requested in a logical sequence as the user works through the 'input' tabs:

- Column shape (circular and rectangular)
- Column dimensions
- Column location (internal, edge, corner or re-entrant corner)
- Dimension to concrete edge (for offset corner and edge columns)
- Slab thickness
- Concrete grade
- Stress through pre-compression
- Reinforcement size and spacing
- Slab reinforcement and cover
- Size and location of slab openings
- Shear load
- Applied moments

This free program can be downloaded from www.ancon.com.au.

Latest Features of the Ancon Shearfix Design Program

Project Management

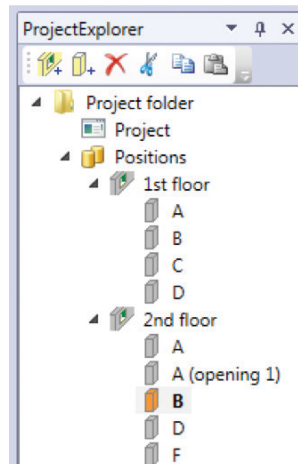

The Ancon Shearfix Design Program contains a calculation management tool, allowing multiple column locations to be designed within a single project file. The calculations can be arranged in a system of sub-directories to ease project management. When exporting design information, any number of column locations can be included in a bulk export as a pdf calculation report, a dxf file or a pdf parts list.

Interactive 2D Graphic Display

A clear 2D graphic automatically updates as data is entered, illustrating the column and opening dimensions, and the locations of openings relative to the column. Each dimension can be edited via the 2D graphic or via the main input window. Furthermore, it is possible to 'grab and drop' the openings via the 2D graphic.

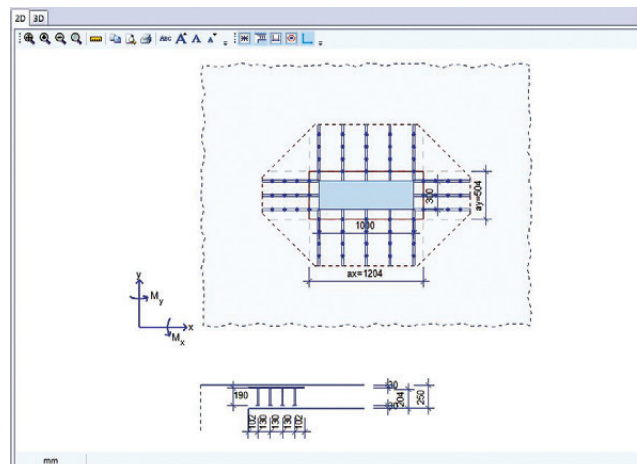

Example of 2D graphic that automatically updates

Slab Openings

Any number of rectangular and circular slab openings can be applied to a design calculation and the software arranges the design solution to suit.

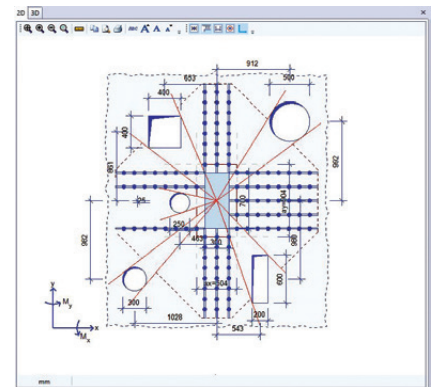

Example of multiple openings

Slab Reinforcement

Where structures contain a layer of tensile slab reinforcement in each direction, the software will automatically calculate the effective slab depth.

The calculation method used in the design program (Lim and Rangan) is shown on page 11.

Punching Shear Reinforcement

Design Information: AS3600 (Australian Standard)

The analysis follows the specifications in the standard AS3600: 2018 clause 9.3, but the major part of the design is based on the research presented by F K Lim and B V Rangan. Please note that AS3600: 2018 does not have a specific clause on shear stud design, therefore the software is based on the research paper. Leviat recommends the shear stud design is verified against an alternate standard such as BS EN 1992 (Eurocode 2) or ACI318 which is also available in the software.

The shear capacity of the slab is checked against the design shear forces at the critical shear perimeter (refer to AS3600: 2018 for further details on determining the critical shear perimeter) and if required Shearfix studs are designed to increase the shear capacity of the slab.

The first stud is positioned between $0.35d - 0.5d$ from the column face. The stud spacing along the rail is a minimum of 75% of the slab thickness, 70% of the stud height and 500mm.

The software calculates the number of rails required by determining the additional strength required from punching shear reinforcement to achieve the necessary capacity within the shear reinforced area.

The software checks the punching shear resistance with two studs per rail first and continues adding more studs until the shear resistance of the slab exceeds the applied punching shear load.

The maximum spacing between individual rails is limited to the minimum of the slab thickness and 600mm.

The last control perimeter for the verification is located at a distance $d/2$ beyond the outermost shear stud of each rail.

Effect of Slab Penetrations

Where there are openings in the slab within $2.5b_0$ (b_0 = width of an opening) from the critical shear perimeter (AS3600: 2018 Cl.9.3.1.2), a section of the slab will be ineffective and the critical shear perimeter will need to be reduced. The design program allows reductions to be applied to the critical shear perimeter as appropriate.

Design Manual

An Ancon Shearfix manual to AS3600/ Lim and Rangan, BS EN 1992 (EC2) and ACI318 is available to download from www.ancon.com.au.

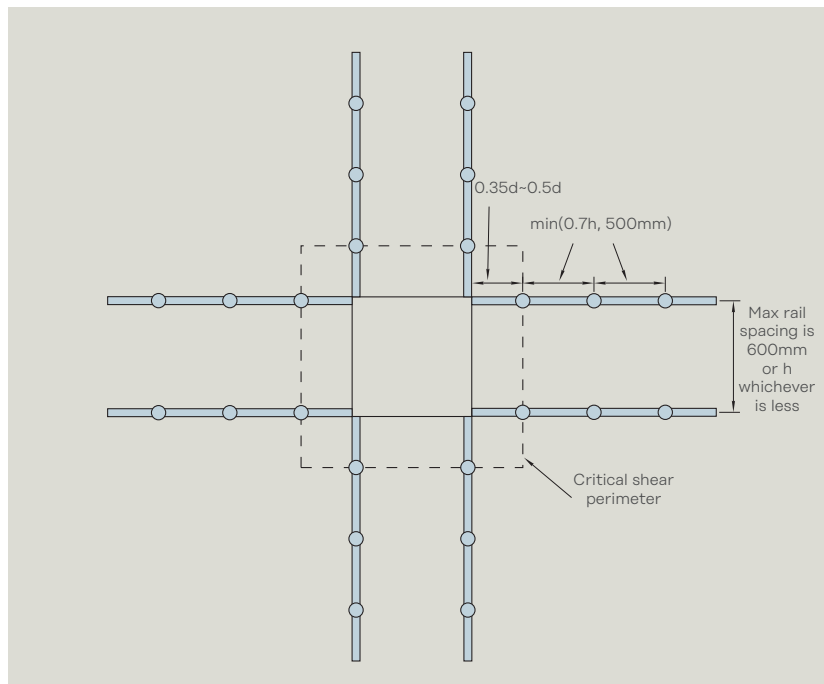

Design Information

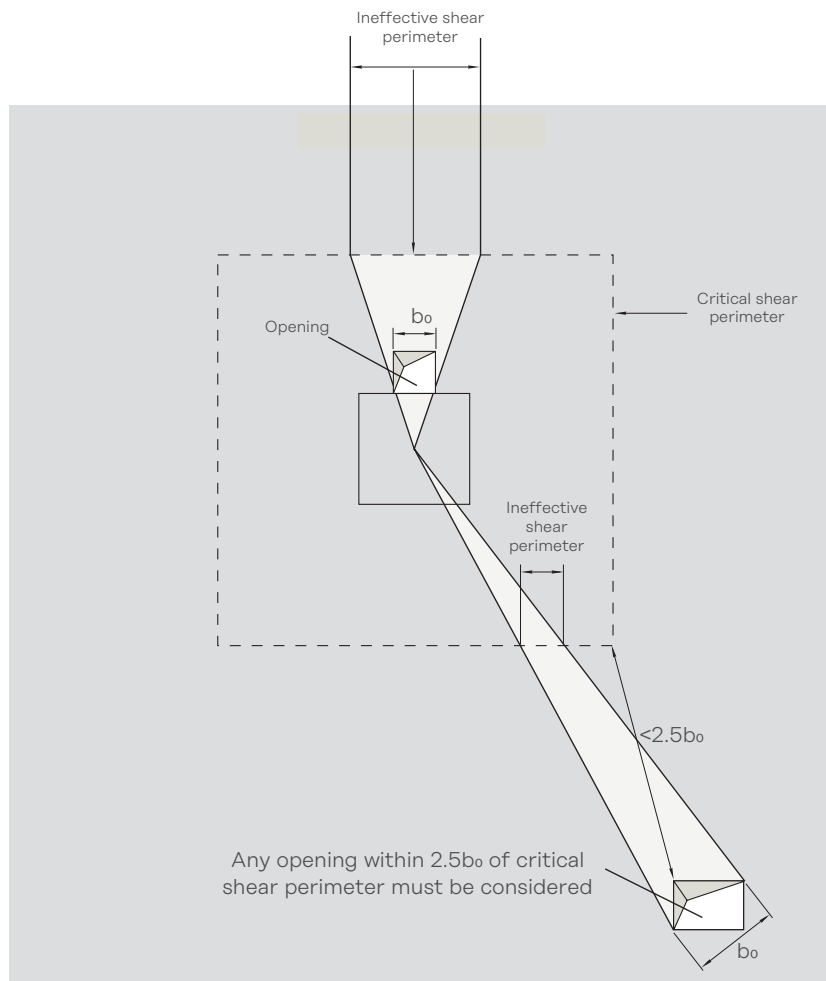

Slab Penetrations

Calculation Method

The design of Ancon Shearfix follows the general specifications set out in Clause 9.3 of AS3600: 2018, but the major part of the design is based on the research presented by F K Lim and B V Rangan from the School of Engineering at Curtin University of Technology in Perth. The design calculations check the shear stresses imposed on the critical shear perimeter surrounding the column, with Ancon Shearfix stud reinforcement provided as required.

Design Actions

When checking the shear capacity of the slab, the design shear force V^* and design transfer moments from the slab into the support $M_{col,x}^*$ and $M_{col,y}^*$ must be taken into account. These values need to be calculated and inserted into the software.

Critical Shear Perimeter

The first critical shear perimeter " u_0 " is the boundary of the effective area of a support or concentrated loads located at a distance of $d/2$, (d = effective depth of the slab).

For rectangular columns:

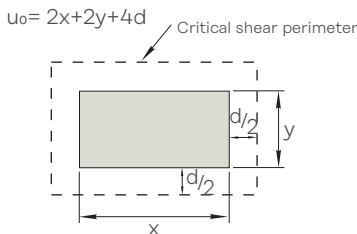

Where there are critical openings within $2.5 b_0$ from the critical perimeter, the projected width of the opening will be ineffective and will reduce the length of the critical perimeter.

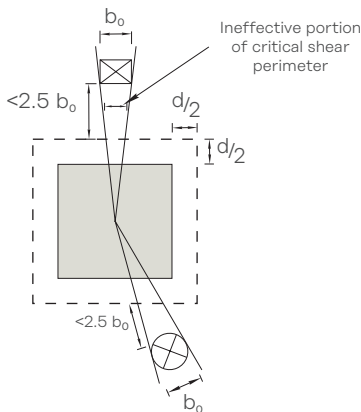

Calculation of Shear Stress

The shear capacity of the slab is determined in accordance with Clause 9.3.3 for the case where there are no transfer moments (M^* is zero), or Clause 9.3.4 for the case where there are transfer moments (M^* is not zero).

For the case where M^* is zero

$$V_{u0} = u_{d0m}(f_{cv} + 0.3\sigma_{cp})$$

Where –

V_{u0} = shear capacity of the slab

σ_{cp} = average pre-stress in concrete

f_{cv} = concrete shear strength

Where –

$$f_{cv} = 0.17(1 + \frac{2}{\beta_n}) \sqrt{f'_c} \leq 0.34 \sqrt{f'_c}$$

β_n is the ratio of the effective loaded area = X/Y ($X \geq Y$)

For the case where M^* is not zero –

$$V_u = V_{u0} / [1.0 + uM_v^* / (8V^* ad)]$$

Where " a " is the dimension of the critical shear perimeter parallel in the direction of M_v^* .

If $V^* > \phi V_u$ or ϕV_{u0} , then Ancon Shearfix studs are required.

To determine the shear capacity of the slab with Ancon Shearfix studs, the following modified Lim and Rangan equations are used:

$$V_u = V_{u0} (0.75 + k)$$

OR

$$V_u = \frac{V_{u0}}{\left(\frac{1}{0.75 + k} + uM_v^* / (8V^* ad)\right)}$$

(the lesser result of the two equations)

where –

$$k = \frac{1}{V_{u0}} A_v \cdot f_{vy} \cdot \frac{d}{s} \cdot \frac{u}{a} \geq 0.25$$

A_v = cross sectional area of a row of studs

f_{vy} = yield strength of the stud (500 MPa)

a = width of the critical shear perimeter perpendicular to the direction M_v^*

To determine the rail length, continue adding studs until the shear stress along the critical shear perimeter located at $d/2$ from the outermost stud is less than the concrete shear capacity.

The Ancon Shearfix Design Program automatically determines the diameter, spacing and number of studs required.

Detailing

The following detailing is used by the software to arrange the Ancon Shearfix rails around the column:

- The position of the first stud from the column face is predefined as $0.5d$ but a value between $0.35d - 0.5d$ can be chosen by the user (d =effective depth of slab)
- The distance between the studs within one rail is a minimum of 75% of the slab thickness, 70% of the stud height and 500mm
- There is always a minimum of 2 rails per column side
- The maximum distance between individual rails is limited to a minimum of the slab thickness and 600mm

Please contact the Leviat technical team on 1300 304 320 or email technical.au@leviat.com should you have any questions about the calculation method or the software.

Punching Shear Reinforcement

Typical Arrangements

Shearfix is suitable for all column shapes and locations. Some typical arrangements are shown here.

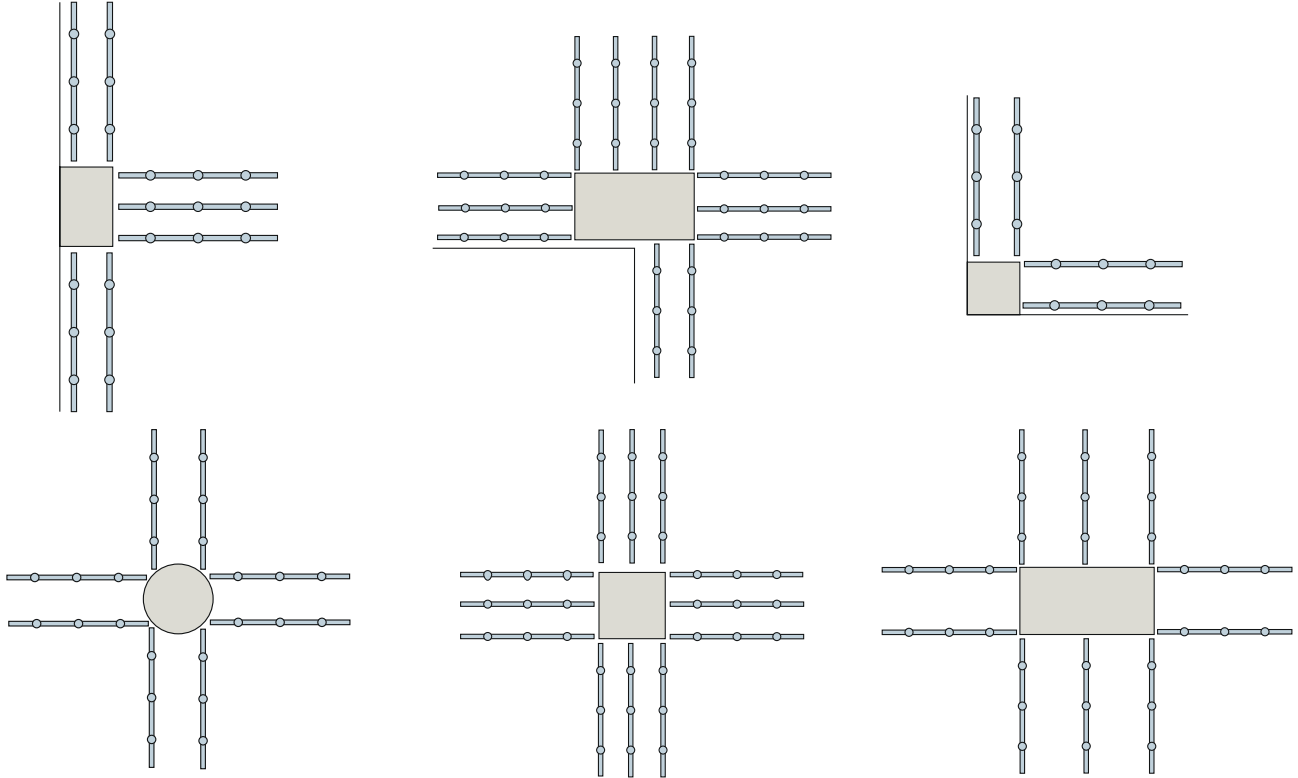

Installation Procedure

Ancon Shearfix is quick and simple to install. It can be fitted either 'top down' (after all other reinforcement) or 'bottom up' (prior to other reinforcement).

The same rail overhang is used at both rail ends. The overhang is equal to the spacing between the column face and the first stud, therefore install the rail end in line with the column face.

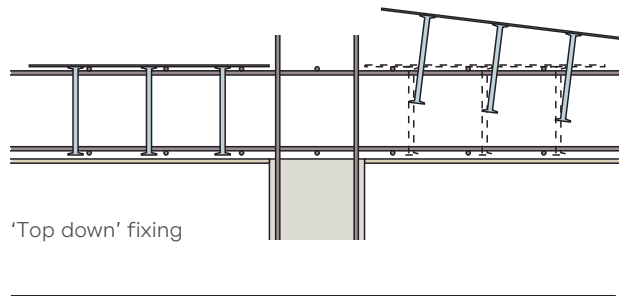

'Top down' Fixing

- Fix all main reinforcement in position
- Place Shearfix rails around the column to the layout detailed on job drawings by passing the studs through the reinforcement grid and resting the carrier rails on the top layer of reinforcement
- Tie rails with wire to main reinforcement and pour concrete

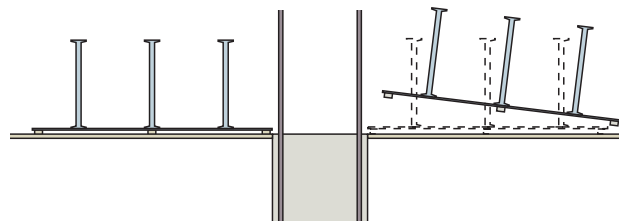

'Bottom up' Fixing

- Clip rails to spacers in order to maintain cover
- Place rail and spacer units around the column to the layout detailed on job drawings
- Fix main reinforcement in position and pour concrete

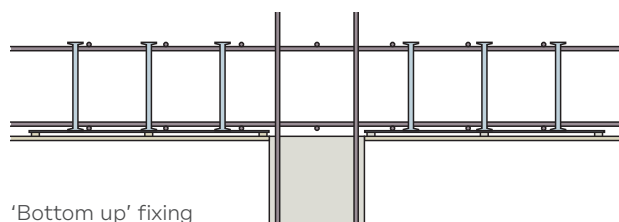

Applications



Photo: Hyder Consulting

Westpac Place, Sydney, NSW



Victoria Point, Melbourne, VIC



Beaumonde Apartments, Sydney, NSW

Other Ancon Products

Reinforcing Bar Couplers

The use of reinforcing bar couplers can provide significant advantages over lapped joints. Design and construction of the concrete can be simplified and the amount of reinforcement required can be reduced. The Ancon range includes BT parallel threaded couplers and MBT mechanically bolted couplers.

Reinforcement Continuity Systems

Reinforcement Continuity Systems are an increasingly popular means of maintaining continuity of reinforcement at construction joints in concrete. The Ancon Keybox system eliminates the need to drill shuttering and can simplify formwork design, thereby accelerating the construction process. It is available in both standard units and special configurations. Ancon KSN Anchors eliminate the need for on-site bar straightening and are available to accept reinforcement of 12mm, 16mm and 20mm diameter. The system is also available with a re-useable rebate former.

Shear Load Connectors

Ancon DSD and ESD Shear Load Connectors are used to transfer shear across expansion and contraction joints in concrete. They are more effective at transferring load and allowing movement to take place than standard dowels, and can be used to eliminate double columns at structural movement joints in buildings. A 'Lockable' dowel is also available for temporary movement joints in post-tensioned concrete frames.

Masonry Support Systems and Fixings

Leviat manufactures support systems for masonry cladding on concrete and steel framed buildings. A wide range of channels and bolts are available to fix these systems to the structural frame. Cast-in channels and expansion bolts are used for fixing to the edges of concrete floors and beams.

Tension Systems

Tie bars are increasingly being used in structures and buildings as an architectural as well as a structural element. Our Tension Systems comprise a range of components which can be supplied in carbon steel or stainless steel in a variety of sizes and finishes. A variety of assemblies can be created from simple tie bars to complex bracing systems involving several bars joined at one point.

Special Fabrications

Leviat is an ASSDA accredited specialist fabricator and has a wealth of experience in working with a variety of material grades. High integrity steel components are supplied to a wide range of industries including Civil Engineering, Building, Infrastructure, Water Treatment, Nuclear and Mining.

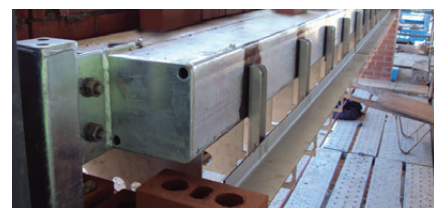

© Darcy Schack JAM Photographics Ltd

© Thiess, Energy Australia

Contact Leviat locally

For more information on the products featured here, please contact Leviat:

General Enquiries

T: 1300 304 320

Leviat.com

Sales Offices and Production

New South Wales, Sydney

98 Kurrajong Avenue
Mont Druitt | Sydney
NSW 2770

Queensland

4/15 Terrace Place
Murarrie | Brisbane
QLD 4172

New South Wales, Casino

10 Irving Drive
Casino
NSW 2470

Western Australia

18 Tennant Street
Welshpool | Perth
WA 6106

Victoria

9/63-69 Pipe Road
Laverton North | Melbourne
VIC 3026

Contact Leviat worldwide

Australia

98 Kurrajong Avenue,
Mount Druitt, Sydney, NSW 2770
Tel: +61 - 2 8808 3100
Email: info.au@leviat.com

Austria

Leonard-Bernstein-Str. 10
Saturn Tower, 1220 Wien
Tel: +43 - 1 - 259 6770
Email: info.at@leviat.com

Belgium

Industrielaan 2
1740 Ternat
Tel: +32 - 2 - 582 29 45
Email: info.be@leviat.com

China

Room 601 Tower D,
Vantone Centre
No. A6 Chao Yang Men Wai Street
Chaoyang District
Beijing P.R. China 100020
Tel: +86 - 10 5907 3200
Email: info.cn@leviat.com

Czech Republic

Business Center Šafránková
Šafránková 1238/1
155 00 Praha 5
Tel: +420 - 311 - 690 060
Email: info.cz@leviat.com

Finland

Vädursgatan 5
412 50 Göteborg / Sweden
Tel: +358 (0)10 6338781
Email: info.fi@leviat.com

France

6, Rue de Cabanis
FR 31240 L'Union
Toulouse
Tel: +33 - 5 - 34 25 54 82
Email: info.fr@leviat.com

Germany

Liebigstrasse 14
40764 Langenfeld
Tel: +49 - 2173 - 970 - 0
Email: info.de@leviat.com

India

309, 3rd Floor
Orion Business Park
Ghodbunder Road
Kapurbawdi, Thane West,
Thane, Maharashtra 400607
Tel: +91 - 22 2589 2032
Email: info.in@leviat.com

Italy

Via F.lli Bronzetti 28
24124 Bergamo
Tel: +39 - 035 - 0760711
Email: info.it@leviat.com

Malaysia

28 Jalan Anggerik Mokara 31/59
Kota Kemuning,
40460 Shah Alam Selangor
Tel: +603 - 5122 4182
Email: info.my@leviat.com

Netherlands

Oostermaat 3
7623 CS Borne
Tel: +31 - 74 - 267 14 49
Email: info.nl@leviat.com

New Zealand

2/19 Nuttall Drive, Hillsborough,
Christchurch 8022
Tel: +64 - 3 376 5205
Email: info.nz@leviat.com

Norway

Vestre Svanholmen 5
4313 Sandnes
Tel: +47 - 51 82 34 00
Email: info.no@leviat.com

Philippines

2933 Regus, Joy Nostalg,
ADB Avenue, Ortigas Center
Pasig City
Tel: +63 - 2 7957 6381
Email: info.ph@leviat.com

Poland

Ul. Obornicka 287
60-691 Poznań
Tel: +48 - 61 - 622 14 14
Email: info.pl@leviat.com

Singapore

14 Benoi Crescent
Singapore 629977
Tel: +65 - 6266 6802
Email: info.sg@leviat.com

Spain

Polígono Industrial Santa Ana
c/ Ignacio Zuloaga, 20
28522 Rivas-Vaciamadrid
Tel: +34 - 91 632 18 40
Email: info.es@leviat.com

Sweden

Vädursgatan 5
412 50 Göteborg
Tel: +46 - 31 - 98 58 00
Email: info.se@leviat.com

Switzerland

Grenzstrasse 24
3250 Lyss
Tel: +41 (0)800 22 66 00
Email: info.ch@leviat.com

United Arab Emirates

RA08 TB02, PO Box 17225
JAFZA, Jebel Ali, Dubai
Tel: +971 (0)4 883 4346
Email: info.ae@leviat.com

United Kingdom

President Way,
President Park,
Sheffield S4 7UR
Tel: +44 - 114 275 5224
Email: info.uk@leviat.com

USA / Canada

6467 S Falkenburg Road
Riverview, FL 33578
Tel: (800) 423-9140
Email: info.us@leviat.us

For countries not listed
Email: info@leviat.com

Notes regarding this document

© Protected by copyright. The information in this publication is based on state-of-the-art technology at the time of publication. In every case, project working details should be entrusted to appropriately qualified and experienced persons. Leviat shall not accept liability for the accuracy of the information in this document or for any printing errors. We reserve the right to make technical and design changes at any time. With a policy of continuous product development, Leviat reserves the right to modify product design and specification at any time.

